

## Design and Manufacturing of LPG Gas Leak Detector in The Kitchen

Muhammad Arif <sup>1,\*</sup>, Azmi <sup>2</sup>

<sup>1,2</sup> Sekolah Tinggi Teknologi Dumai

Jl. Utama Karya Bukit Batrem II, Dumai, Indonesia

[doi.10.22216/JoD.2017.V2.27-32](https://doi.org/10.22216/JoD.2017.V2.27-32)

\*Correspondence should be addressed to [pakarifmt@gmail.com](mailto:pakarifmt@gmail.com)

Copyright © 2017 M. Arif. This is an open access article distributed under the [Creative Commons Attribution License](https://creativecommons.org/licenses/by/4.0/).

### Article Information

Received : 20 Feb 2017

Revised : 28 Apr 2017

Accepted : 29 May 2017

Published : 31 May 2017

### Abstract

How to detect a gas leak is by using an early detection to prevent the occurrence of unwanted conditions. Detector as a gas leak detector can be applied to reduce the incidence of unwanted conditions such as explosion and fire that can result material losses, even death. The most common cause of the leak gas cylinders is corrosion in the gas cylinder, hose and its regulator. However, another cause is forced modification that can create accessories damage such as hose, valve, and regulator. Based on above conditions, additional effort is needed to maintain fire accident due to gas leak from cooking device that uses gas to cook in the kitchen or housing residents. Therefore, there was an action to design a leak gas detector ergonomically, effectively, and efficiently. From its function, detector can react 6 seconds if the position is above of regulator, and 9 seconds if placed on the above of stove at 35 cm distances. After the designed detector is completed and also tested, then detector was able to detect the occurrence of leak gas and it is useful to be used by the public.

**Keywords:** detector, design product, ergonomics

## 1. Introduction

The number of incidents of fire and explosion of LPG gas cylinders had become a hot issue at the beginning of the gas conversion program undertaken by the government. Apart from the lack of public knowledge about the operation and maintenance of gas stoves, hoses, regulators, and tubes, the incident of fire and explosion of LPG gas cylinders can also be caused by the quality of gas stoves, hoses, regulators and gas cylinders themselves causing gas leaks triggering explosions and fires [1].

The detector is a series of devices equipped with sensor units, process units, and indicator units used to detect, track, or identify particles, substances, magnetic fields, or radiation and other forms of energy [2].

Detector functions can be applied in everyday life, such as metal detectors, heat and cold detectors, gas leak detectors and many more uses.

The detector as a gas leak detector can be applied to reduce the incidence of unwanted things such as explosions and fires [3].

Given the need to reduce the fire disaster caused by the gas stove, to design a detector that can detect the occurrence of gas LPG leakage that will be very important role [4].

Design is a process that aims to analyze, assess the repair and arrange a system, both physical and non physical systems are optimum for the future by utilizing existing information. The design of an instrument is included in the engineering method, thus the designing steps will follow the engineering method [5].

Leak detector is a device that can perform leak check on an area. This device is commonly used as a security system to detect leaks with automatic control systems making it easier to handle leaks [6].

Gas sensor is a tool component to read the existence of a type of gas in a place, usually this sensor is used in a safety system. This type of sensor is used to detect gas leaks and connect to a regulatory system to cover any processes that cause or leak gas. Gas sensors can also sound the alarm to be known by the supervisors who are in the vicinity of the gas leak occurred so that workers in the area can immediately conduct an evacuation so as to prevent something worse. This tool is very important to avoid the events that can threaten the lives of workers and animals or plants that are around the area, because some types of gas can be very dangerous [7].

TGS2610 sensor is one type of sensor commonly used to detect gas leakage. This sensor is a metal-oxide semiconductor, the sensor layer is formed above the substrate aluminum oxide. This sensor is a chip incorporated with an integrated heating device. If there is a gas, the sensor conduction will increase, the conductivity of the sensor increases depending on the concentration of gas in the air. A simple electrical strand can convert in a change in conductivity to an output signal that corresponds to a concentration gas attached.

#### A. Definitions Operations Process Chart

In this research use explanation of detector making by using Operation Process Chart. The operating process chart is a chart that describes the process sequences or inspection operations, the time of leeway, and the use of material in the production process systematically and clearly from the beginning of the raw material to the finished product as a whole and as a component. Such as time spent, materials used, and place or tool or machine used [8].

#### B. Break Event Point

This research using BEP (Break Event Point) is an analysis technique to study the relationship between fixed cost, variable cost, profit and activity volume. A new BEP issue will appear in the company if the company has Variable Costs and Fixed Costs. A company with a certain volume of production can suffer losses because its sales revenue is only able to cover variable costs and can only cover a small portion of fixed costs [9].

#### C. Definitions Ergonomics

The ergonomics is derived from the Latin "Ergo" means Work and "Nomos" means rule or principle. In the other word, the ergonomics is a study that describes relationship between human and its work. In detail, ergonomics can also be

defined as a study about human aspects in work environment that is reviewed from anatomy aspect, physiology, psychology, engineering, management and design. Ergonomics also are related with efficiency, health and safety [10].

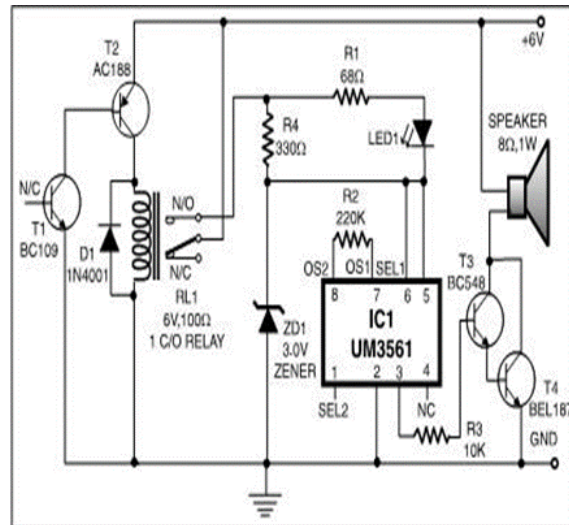

Figure 1. Initial Design of LPG Gas Leakage Detector Circuit.

## 2. Material and Methods

This research was conducted in Production Process Laboratory of STT Dumai. The study took place in April 2016 until June 2016. A Gas Leak Detector design consisting of:

1. Relay is useful as the regulator of electric life death
2. PCB Board A board full of electronic components.
3. Buzzer is useful as a loudspeaker
4. LED light component of electronics emits light.
5. Sensor TGS a tool that reads what if there is a leak.
6. Voltage down transformer.



Figure 2. Initial Design of LPG Gas Leakage Detector



Figure 3. Initial Assembly of LPG Gas Leak Detector Equipment.

Source: Research Data 2016.

### 3. Result and Discussion

The data collected in this research is the equipment data needed to design the detector equipment that suits the needs of its working function.

In doing this research the authors use the work map so that all the steps traversed from the beginning to the end of making the tool can be seen through the working map used. The working map used is the operation process chart (Operation Process Chart).

There are several stages in making LPG Gas Leak Detector tool that is:

1. Provide advance materials that have been needed.
2. Provide supporting tools in the work of LPG gas leak detector equipment, such as solder, screwdriver, pliers, scissors and meter.

While the steps in the manufacture of LPG Gas Leakage Detector tools are:

#### *Designing the Detector Box*

1. Better first provide a box of callista that can be purchased 10x10 cm size.
2. Measure a large detector using a meter to ensure that the size of the callista is needed.
3. Then double-check the size using the meter to avoid errors during assembly.

#### *Design of PCB detector circuit in general*

1. First provide a PCB detector board that can be purchased at an electronics store.
2. Tidy back the PCB board and add LED lights, relays, AC / DC transformer.
3. Check back PCB boards and LED lights LED lights, relays, AC / DC transformers.
4. Put the PCB board on the bottom of the callista with Satanic glue.

#### *Design the addition of DC Power*

1. First provide DC power and then measured DC power using a meter for the size of the battery.
2. Provide an almanium plate as a DC position.
3. Measure the diameter on the almanium plate according to the diameter on DC then cut the almanium using scissors.
4. Check the size of the DC shield to ensure the accuracy of the DC position.\
5. Glue the DC position using the glue of the demon and the glue gun refilla so that the de positions do not shake.

Once everything is done designed make sure the state of the size and power of the tool is in a state of true and strong. Then make a tool that serves as a gas leak detector LPG tool. Which can alleviate or assist the activities of housewives more safely.

#### *Detector Assembly*

The very first thing I do is do and compile the components that will be displayed on the cover, this the author did to arrange the best position for each component.



Figure 4. Component Structure in cover

When the Researcher considers the position of each component is fixed as needed, then the next step is to connect each component according to its function. Researchers used a single core cable soldered to each of the major components, in this case PCB transformers, relays and batteries.

#### *First Testing*

The researcher performs the first test after all components are connected. In the first test phase, the author makes two sessions of test with AC input and test with DC input.

### AC Input Testing

This test is performed to determine whether the transformer is working properly when tested. When tested, the appliance lights up with a short buzzer marked once, followed by the LED (red and green) lights simultaneously, then the red LED light goes off. Only the green LED lights up as an indicator tool in standby condition.



Figure 5. Green Led Lights on

### DC Input Testing

This test is intended to determine whether the relays and input from the battery work in accordance with expectations. When tested, the researchers disconnect the AC input immediately, and what happens is the relay works automatically move the AC power input to DC. This is indicated by a "click" on the relay and the green LED is relayed on. This condition is enough to prove that the relay and battery work according to which the author hopes.

After all the components are installed, the researcher closes the flat side and the sunken side of Calissta carefully until it closes properly. The researchers added a glue gun to seal around the edges of calissta and mini fan holes. The goal is that this container Calissta really vacuum when the mini fan works. Expected with such conditions, the air being inhaled by the mini fan is completely derived from the hose.

The final step is to install the right hose tip of the TGS2610 sensor. This hose is also a hole researcher with a diameter of 2mm every 30cm distance starts from the nearest end of the gas source. The purpose of these small holes for leakage of gas hoses is also detected, not just on gas sources alone. The edge of the hose that goes into calissta is also a seal researcher with a glue gun with the same purpose.

### Final Testing

After all assembly steps are completed, the researcher performs the final test. This test is performed in the following manner:

1. Connect the appliance to the AC outlet, AC input is used, switch the manual off switch on.
2. LPG gas is thrust for 1 second starting from the end of the furthest hose to the nearest hole with calissta.
3. The researcher recorded an active alarm response time at each test point, using a stop watch.
4. Unplug the outlet, auto relay switch works, DC input is used.
5. Repeat step on point 2
6. Repeat step on point 3

The test results at the time of active alarm response are shown in the following table:

Table 1. Test results Average time of active alarm response  
Source: Research Data, 2016

No	Position	Distance /cm	Seconds
1	Above the Regulator	10	6
		20	7
		30	10
		40	13
		50	18
2	On the stove	35	9
		43	10
		52	13
		61	16
		74	20

From the table it appears that the closer the test point, then the time required for the sensor to detect the leakage of LPG gas is also faster on average.

### Break Event Point (BEP)

Break Event Point (BEP) is the point where Entity / company / business is in a state of profit yet, but also has no loss, from result of material data processing and price list of materials needed researcher can calculate Break Event Point (BEP) with the following calculation.

Table 2. The cost of using LPG Gas leakage detector manufacture.

No	Cost	Price (Rp)	Total Cost
1	Fixed Cost		
a	Cost of Multimeter Rent	11.500	
Total Fixed Cost			11.500
2	Variable Cost		
a	Material Cost	305.500	
b	Overhead Cost	3.000	
Total Variable Cost			308.500
Total Production Cost			320.000

Source: Research Data, 2016

Break Even Point unit calculation is:

$$\text{BEP Unit} = (\text{Fixed Cost}) / (\text{Cost of Production} - \text{Variable Cost per Unit}) \quad (1)$$

$$\text{BEP Unit} = 11500 / (320.000 - 308.500)$$

$$\text{BEP Unit} = 11.500 / 11.500$$

$$\text{BEP Unit} = 1$$

The calculation of Break Event Point Rupiah is:

$$\text{BEP Rupiah} = (\text{fixed cost}) / (\text{Contribution Margin per Unit} / \text{Cost of Production}) \quad (2)$$

$$\text{BEP Rupiah} = 11,500 / (11,500 / 320,000)$$

$$\text{BEP Rupiah} = 11.500 / 0.03$$

$$\text{BEP Rupiah} = 383333,33$$

$$\text{BEP Rupiah} = \text{Is set to Rp. } 384.000,$$

Calculation of Selling Price Per Unit is:

$$\text{Selling Price Per Unit} = \text{BEP Rupiah} + (\text{BEP Rupiah} \times 10\%) \quad (3)$$

$$\text{Selling Price Per Unit} = 384,000 + (384000 \times 10\%)$$

$$\text{Selling Price Per Unit} = \text{Rp. } 422.400,$$

Through the calculation of BEP in the price of each unit of LPG gas leak detector is Rp. 422,400,

Where the BEP Rupiah plus the profit taken is 10% of BEP Rupiah.

#### 4. Conclusion

The conclusions that can be drawn from this research are:

1. Maximize the function of TGS2610 sensor by adding mini fan and small hollow hose, so hopefully the tool can become more sensitive with the existence of gas in the room.
2. Most marketed devices have only AC inputs, so that when the AC input from the PLN is off, the appliance will not work. With the addition of DC inputs from a battery equipped with an autoswitch relay, this can be easily overcome.
3. With a small hollow extending hose directed to the proximity of a portion at which the gas

leak is at risk, the operating distance of the appliance may be more rapidly reacting.

#### Suggestion

Suggestions to be given for further development or research steps:

1. The design of this type of detector for subsequent research should be made with a more solid cover to avoid unintentional impacts that may cause the detector's malfunctions.
2. For further research it should be possible to install additional LCD function which can show the variable of default indoor air value and variable of gas exposure value detected.

#### References

- [1] T. Sutalaksana, Teknik Perancangan Sistem Kerja, Bandung, Penerbit ITB. 2012, pages[32]
- [2] T. Daniel, Perancangan Alat Pendeteksi Kebocoran Gas LPG dengan Menggunakan Sensor TGS-2610 Berbasis Mikrokontroler AT89S51, ISSN: 0854-3844, 2010, pages[94]
- [3] R. Ginting, Perancangan Produk, Yogyakarta, Graha Ilmu. 2009, pages [110]
- [4] A. Kunto, Air Flow Control System Based Microcontroller to Prevent Fires Due to LPG Gas Leak. 2011, pages[44]
- [5] Maulana, Marketing Management, Jakarta, Gramedia Pustaka Utama. 2013, pages [78]
- [6] S. Robbins, Penelitian dan Pengembangan Produk, Jakarta, Erlangga, 2011, pages[102]
- [7] P. Maulana, Rancang Bangun Pendeteksi Kebocoran Gas LPG Menggunakan Sensor TGS2610, 2012, pages[23]
- [8] Nurhalimah, Anaalisis Pengaruh Konsentrasi Gas LPG Menggunakan Sensor TGS-2610 berbasis mikrokontroler AVR atmega8535, ISBN: 979-26-0277-3, 2011, pages[66]
- [9] G. Santoso, Ergonomi Terapan, Jakarta, Prestasi Pustaka Publisher. 2013, pages[21]

- [10] Budiyo, Pendeteksi Kebocoran Tabung Gas LPG Menggunakan Mikrokontroler At89s2051, ISSN: 1410-9565, 2008, pages[67]